



Powering Business Worldwide

Aerospace Group
Conveyance Systems Division

Carter® Brand
Ground Fueling

SM64349

April 2011

Applicable additional manuals:

SM64019 2" Unisex Non-valved Coupling
SM64020 2" Unisex Valved Coupling
SM64031 3" Unisex Valved Coupling
SM44646 Hose End Regulator
SM349MISC Miscellaneous Adapter Assemblies
SM40679 60427 Type QD Assemblies
SM61154 Dry Break Disconnect Assy
SM64015 Ball Valve
SM64245 Low Pressure Drop Dry Break QD

Maintenance Manual

Pressure Fueling Nozzle

Model 64349

TABLE OF CONTENTS

	PAGE
1.0 INTRODUCTION	3
2.0 EQUIPMENT DESCRIPTION & OPERATION	3
3.0 TABLE OF OPTIONS AND ORDERING INFORMATION.....	4
4.0 SAFETY INFORMATION.....	6
5.0 SPECIAL TOOLS	9
6.0 DISASSEMBLY.....	9
7.0 INSPECTION.....	11
8.0 REASSEMBLY.....	11
9.0 TEST.....	12
10.0 ILLUSTRATED PARTS CATALOG	14
FIGURE 1 - CHART OF OPTIONS AVAILABLE	15
FIGURE 2 - CURRENT PRODUCTION CONFIGURATION.....	17
FIGURE 3 - PREVIOUS CONFIGURATION	19
FIGURE 4 -ADDITIONAL OPTIONS	21
FIGURE 5 - CONTINUITY CLIP INSTALLATION	22
FIGURE 6 - POPPET-SHAFT RETENTION.....	23
11.0 FAILURE MODES AND EFFECTS ANALYSIS.....	24
12.0 FAILURE MODES AND EFFECTS ANALYSIS – HOSE END CONTROL VALVE	29

Maintenance, Overhaul & Test Instructions

Eaton's Carter® Brand Model 64349

Pressure Fueling Nozzle

1.0 INTRODUCTION

This manual furnishes detailed instructions covering the maintenance and overhaul of Eaton's Carter brand Model 64349, Pressure Fueling Nozzle and its various options.

There are specific manuals available for nozzles that are qualified in accordance with MIL-N-5877 and are designated D-1 and D-2 nozzles. These manuals are SM64349H and SM64349J respectively. There is also a manual for the special nozzle used by the U.S. Army

and Marine Corps, 64349CDK, manual SM64349CDK. These three manuals are more specifically written to cover the special options only and do not include all possible options as this one does.

For the maintenance of options to the basic 64349 nozzle, refer to Options Table, Section 3.0. This table will reference the service manual that should be used in the maintenance of each option.

2.0 EQUIPMENT DESCRIPTION & OPERATION

2.1 DESCRIPTION

Model 64349H is a 2-1/2 inch pressure fueling nozzle that has been qualified to MIL-N-5877, Rev E and listed on that QPL as the D-1 nozzle. The 64349J is qualified to MIL-N-5877, Rev E and listed on that QPL as the D-1 nozzle. The mil-spec does not allow for all of the options shown in this manual but they can be procured as noted herein. The unit is designed to mate with adapters conforming to MS24484 or equivalent. Models 64349H and J supersede the previously qualified Models 61429H and 61429J respectively. The difference between the nozzles is centered around the collar-operated lever geometry and the interlock pin shape. The new collar-lever geometry improves operational safety, even with aircraft adapters worn to the limits. The change in the interlock pins improves collar wear. In addition the 64349 Nozzles have replaceable stick handles.

The basic nozzle would be procured under the part number 64349 which includes the standard stick handles and dust cap. Other options that are available to build a nozzle to specific specifications are listed in the table shown in Section 3.0. The exploded views in the figures at the end of the manual include the various options available.

Older Model 61429 Nozzles can be converted to the newer model by obtaining the appropriate kit of parts. Refer to upgrade manual UP64349.

2.2 OPERATIONS

2.2.1 SAFETY INTERLOCKS

It is vital that each nozzle operator understand that there are several safety interlock features

designed into the 64349 nozzle that must be functioning to prevent an accident that would result in spill of flammable liquids with the consequential risk of fire, personal injury or death, and property damage. Refer to Table 1.0 and Figures 1, 2 and 3 to identify individual parts during the following discussion.

2.2.1.1 COLLAR LOCK AND INDEX PINS

Examination of the connection end of a disengaged nozzle (nozzle not connected to an adapter) discloses the three Collar Lock Pins (19) and three Index Pins (21) installed between the Collar (8) and the nozzle Seal (43).

The three spring-loaded Collar Lock Pins (19) engage three cutouts (arched shaped windows) in the flange of the Collar (8) when the Collar (8) is in the full dis-engaged position and these Collar Lock Pins (19) prevent accidental rotation of the Collar (8) of the disengaged nozzle. Two of the three cutouts in Collar (8) are normally elongated more than the other one.

With the collar (8) locked in the disengaged position, the flat portion of a ramp integral to the Collar (8) is positioned over a flat on the Lever (14) in a manner that prevents opening the Poppet (15).

The three Index Pins (21) mate with three slots in a serviceable MS24484 Adapter Flange to index the nozzle to the flange so the Collar (8) mates with the flange lugs during engagement and prevents disengagement of the Collar (8) from the flange without releasing the three spring-loaded Collar Lock Pins (19) to the collar lock positions.

2.2.1.1 LEVER/COLLAR INTERLOCK AND OVER CENTER LINKAGE

Examination of the center portion of the Lever (14) on a disengaged nozzle discloses the fact that a portion of the edge of the Lever (14) is beneath the flat portion of a ramp that is integral to the Collar (8). With the Collar (8) locked by the Collar Lock Pins (19), the Collar (8) ramp prevents rotation of the Lever (14) to the poppet open position. When the Collar (8) is fully engaged to a serviceable MS24484 Adapter, the Collar (8) ramp clears the Lever (14) and permits Lever (14) oration to the open position. With the Lever (14) full open, the round portion of the Lever (14) prevents rotation of the Collar (8) in the disengage direction until the Lever (14) has been fully closed. These interlocks are designed to prevent accidental opening of the poppet of a disengaged nozzle or accidentally dis-engaging a nozzle with the poppet open.

The poppet operating internal linkage design is such the linkage is over center at each extreme of travel (lever full open against internal mechanical stop or full closed against internal mechan-ical stop).

Thus, internal pressure against a closed poppet, when the linkage is against the closed mechanical stop, provides a force only in the closed direction.

In a similar manner, with the lever in the full open/mechanical stop position, the 50 lb. force applied by the MS24484 Adapter Poppet Spring provides a force only in the open direction.

Refer to Service Bulletin SB3480801A for the latest information on the Lever (14) as it related to safety. Ask Eaton or your Eaton Carter brand distributor for a copy if you do not have one.

2.2.2 OPERATING INSTRUCTIONS

2.2.2.1 OPERATING NOTES AND WARNINGS

The nozzle was designed to be operated in a fully open position or to be closed. No middle point is provided in the design.

STRONG WARNING!

The nozzle was not designed to be used with the operating handle in a partially open position as is the practice of some segments of the services. The handle is not a flow indicator and operating the nozzle in such manner is strongly not recommended as being a safe practice. If the interlock system is worn the nozzle could be removed from the aircraft in an open position causing a spill.

2.2.2.2 THERMAL EXPANSION

WARNING!

Do not leave the nozzle full of fuel and in a completely closed off environment if the temperature is rising. If stored on its hose the hose will off-set some of the temperature increase. A thermal relief system should be employed if the nozzle is to be stored in such a condition.

The nozzle is designed for operation up to and including pressure of 180 psi. (Actually, the nozzle will withstand and is tested to 300 psi but the military specification has a burst pressure rating of 180 psi. Burst pressure is the pressure that the nozzle can withstand without structural damage but need not be operable after being subjected to that pressure). Pressures caused by thermal changes, thermal expansion can rise dramatically. A temperature change of just 30 degrees in a closed nozzle can raise the pressure within the unit to over 500 psi. The 30 degree temperature change can be from - 10° to +20° F or any other change of this magnitude. The temperature does not have to be high at all to cause the pressure to increase.

WARNING!

The use of unisex couplings with a valve or any other valve on the inlet of the nozzle is not recommended and is provided only at the request of the customer. If used and the nozzle/unisex coupling is removed from the hose for storage, drain the nozzle of liquid before storing.

3.0 TABLE OF OPTIONS AND ORDERING INFORMATION

The following table should be used to determine the service manual to be used in the maintenance, repair or replacement of parts designated by option letters to the basic 64349 nozzle.

Option Letter	Part Number	Service Manual
A	44373-40 (1)	SM61154, SM64020, SM64031 or SM40679
B	44373-60 (1)	SM61154, SM64020, SM64031 or SM40679
C	44373-100 (1)	SM61154, SM64020, SM64031 or SM40679
D	44311	SM64349
E	41599	SM64349
F(2)	44646-(2)	SM44646
H	44327	SM349MISC(3)
J	44326	SM349MISC(3)
K	44325	SM349MISC(3)
M	64031H	SM64032
N	47566	SM349MISC
R	44807-2	SM64349
V	64019NV	SM64019
W	47063	SM349MISC
X	64019N	SM64019
2	43045-1	SM349MISC
3H, 3P	64015	SM64015
5	64020N	SM64020
6H, 6L, 6P	61154	SM61154
6Y, 6YH, 6YL, 6YP	64254	SM64254
7H, 7L, 7P	61154	SM61154
9	44362	SM348MISC
9H, 9L, 9P	43108-1 thru -6	SM40679

- Notes:
1. Standard Screen shown, some options utilize 41767-**, 47115-** or 47307-100 in lieu of 44373-**. ** indicates that the mesh size must be added to get a complete part number, e.g. 44373-**.
 2. The part number shown is not complete and must include the spring setting (35, 45 or 55) to achieve a complete number. The actual hose end regulator utilized will depend upon the inlet configuration chosen. See Figure 1.
 3. Special manuals are available for 64349H, 64349J and 64349CDK on request.
 4. Safety clip (P/N 210641) for the 61154 dry break QD is considered FOD (Foreign Object Damage) and is not included on military nozzle assemblies, however, it can be added as a no cost option.

The part number of a complete nozzle consists of four basic parts as illustrated below.

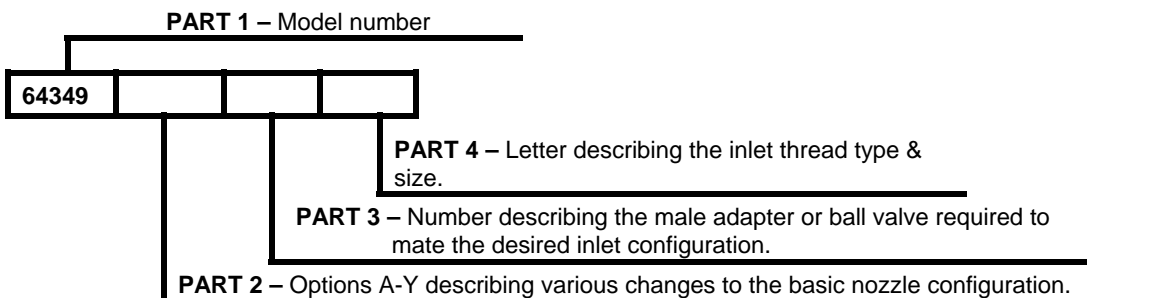

PART 2

The following options may be added as Part 2 of the part number as indicated above to order a unit to meet your requirements:

OPTION LETTER	DESCRIPTION	OPTION LETTER	DESCRIPTION
*A	Adds 40-mesh Screen	J	Adds Straight Inlet with Military Flange.
*B	Adds 60-mesh Screen	K	Adds QD with 2" Female Camlock Inlet.
*C	Adds 100-mesh Screen	M	Adds 3" Valved Unisex Coupling to Inlet.
D	Adds Bonding Cable	N	Adds Universal (D-1/D/2) Inlet
E	Adds Vacuum Breaker	R	Adds Circular Handle Grip.
F3	Adds 35 psi Hose End Regulator	V	Adds Green Unisex Coupling to Inlet.
F4	Adds 45 psi Hose End Regulator	W	Adds MIL-C-24356 Coupling to Inlet.
F5	Adds 55 psi Hose End Regulator	X	Adds Tan Unisex Coupling to Inlet.
H	Adds 45° Elbow Inlet with Military Flange.	Y	Adds Military Bonding Cable (15')

* Options A, B & C only available when a male half or a ball valve from Part 3 or Options V or X is specified.
Option A not available with Option 2 or 9.

PART 3

One of the numbers below must be included as Part 3, as indicated above, to specify the type of inlet configuration desired. The nozzle may be ordered with the inlet terminating in an adapter half only if desired. In this case leave Part 4 blank. If a female half, either quick disconnect, ball valve or dry break of some configuration is desired, Part 4 must be completed.

OPTION LETTER	DESCRIPTION	OPTION LETTER	DESCRIPTION
2	Adds male half adapter to options H or J to connect to 60427 type quick disconnect.	3	Adds ball valve to options H or J. See SM64015 for details concerning the operating handles and defueling key.
5	Adds Valved 2" Unisex Coupling	6	Adds military male adapter half to mate 61154 dry break disconnect.
6Y	Adds male adapter half to mate 64254 Low Pressure Drop Dry Break.	7	Adds male adapter half to mate 61154 Dry Break when regulator is used.
8	Adds male adapter half to mate 61154 Dry Break when regulator is not used.	9	Adds male adapter half to mate with 60427 style quick disconnect.

PART 4

One of the following letters must be included as Part 4 as indicated above to specify the inlet thread and size:

OPTION LETTER	DESCRIPTION	OPTION LETTER	DESCRIPTION
H	Inlet thread – 2½" NPT	P	Inlet thread – 2" NPT
L	Inlet thread – 3" NPT	*S	2" Female Camlock Inlet
Example:	64349H – Standard D-1 Nozzle with 6-bolt inlet flange and 45° inlet flange. 64349J – Standard D-3 Nozzle with 6-bolt straight inlet flange. 64349CF5H3DEH – 64349 Nozzle with 55 psi regulator and ball valve with 100-mesh strainer, drag ring and glass inspection lid with 2½" NPT inlet		

4.0 SAFETY INFORMATION

There are several safety interlock features designed into the 64349 Nozzle that must be functioning to prevent an accident that would result in a spill of flammable liquids with the consequential risk of fire, personal injury or death, and property damage. Refer to Table 1.0 to identify individual parts during the following discussion.

4.1 COLLAR ASSY LOCK AND INDEX PINS

Examination of the connection end of a disengaged nozzle (nozzle not connected to an adapter) discloses the three Collar Assy Lock Pins (19) and three Index Pins (21) installed between the Collar Assy (8) and the Nozzle Seal (41). Refer to Figure 2. The three spring-loaded Collar Assy (8) Lock Pins (19) engage three cutouts (arched shaped windows) in the interior flange of the Collar Assy (8) when the Collar Assy (8) is in the fully disengaged position. These Collar Assy Lock Pins (19) prevent accidental rotation of the Collar Assy of the disengaged nozzle. One of the three cutouts in Collar Assy (8) is normally narrower than the other two. This assures that, even with badly worn adapters, a minimum of two Lock Pins (19) will be activated to prevent the nozzle from being opened when not connected to an adapter.

With the Collar Assy (8) locked in the disengaged position, the flat portion of a ramp integral to the Collar Assy (8) is positioned over a flat on the Lever (14) in a manner that prevents opening the Poppet (15).

When connecting to an aircraft, the Index Pins (21) mate with three slots in a serviceable MS24484 Adapter Flange to index the nozzle to the flange so the Collar Assy (8) mates with the flange lugs during engagement and prevents disengagement of the Collar Assy (8) from the flange without releasing the three spring loaded Collar Assy Lock Pins (19) to the Collar Assy (8) lock positions.

4.2 LEVER/COLLAR ASSY INTERLOCK AND OVER CENTER LINKAGE

Examination of the center portion of the Lever (14) on a disengaged nozzle discloses the fact that a flat edge of the Lever (14) is beneath the flat portion of a ramp that is integral to the Collar Assy (8). With the Collar Assy (8) locked by the Collar Assy Lock Pins (19), the Collar Assy (8) ramp prevents rotation of the Lever (14) to the poppet open position.

When the Collar Assy (8) is fully engaged to a serviceable MS24484 Adapter the Collar Assy ramp clears the Lever (14) and permits Lever (14) rotation to the open position.

With the Lever (14) fully open, the round portion of the Lever (14) prevents rotation of the

Collar Assy (8) in the disengage direction until the Lever (14) has been fully closed.

These interlocks are designed to prevent accidental opening of the poppet of a disengaged nozzle or accidentally disengaging a nozzle with the poppet open.

The poppet operating internal linkage design is such that the linkage is "over center" at each extreme of travel (Lever (14) fully open against internal mechanical stop or fully closed against internal mechanical stop).

Thus, internal pressure against a closed poppet, when the linkage is against the closed mechanical stop, provides a force only in the closed direction.

In a similar manner, with the Lever (14) in the fully open/mechanical stop position, the 50 lb. force applied by the MS24484 Adapter Poppet Spring provides a force to maintain the open direction.

Refer to Service Bulletin SB3480801A for the latest information on the Lever (14) as it relates to safety. Ask Eaton or your Eaton Carter brand distributor for a copy if you do not have one.

4.3 SAFETY INSPECTIONS

Note: The frequencies recommended for the following inspections are our recommendations based on nozzles that have been in daily service for at least a year. The frequency that is required will depend upon the degree of maintenance extended to the equipment and to the age of the equipment. It is not possible for Eaton to recommend other than the safest possible frequencies.

4.3.1 NOZZLE INSPECTIONS – AT EACH REFUELING OPERATION

The following inspections of the Nozzle are recommended at each refueling operation:

A. Inspect the connection end and verify that the Index Pins (21) are intact, in place, and not excessively worn or damaged. Verify that all three Collar Lock Pins (19) are intact, undamaged and **are extended and engage all three cutouts in the Collar Assy (8) and physically prevent Collar Assy (8) rotation.**

This inspection can be accomplished without interruption of the normal operating procedure and without adding appreciably to the operation time by training the operator to automatically observe the connection end of the nozzle upon disconnection from the aircraft. If the Collar Lock Pins (19) do not spring into their correct position, it could mean that the aircraft adapter is defective and should be inspected (see paragraph 4.3.3) and reported as possibly being defective. If the Collar Lock Pins (19) are not extended and engaged in all three cutouts in the

Collar Assy (8), the operator should squeeze the Lever (14) and Handle Grip (4) together while observing the connecting end of the nozzle. This should cause the Collar Lock Pins (19) to "spring" into the cutouts in the Collar Assy (8). If not, then the nozzle should be taken out of service.

B. Prior to engagement to an aircraft inspect the Lever (14) for cracks or looseness with the Screw (39) that attaches it to the nozzle. **Do not use the nozzle if cracks or looseness is apparent.**

C. Upon engagement to an aircraft and opening the nozzle but before operating the deadman control it is recommended that the operator attempt to remove the nozzle from the aircraft. This should not be possible. If it can be removed, either the nozzle was never fully engaged onto the aircraft or needs repair, or the aircraft adapter, is in need of repair or replacement.

4.3.2 NOZZLES INSPECTIONS – MONTHLY BASIS

The following inspections of the nozzle are recommended to be conducted on a monthly basis as a minimum:

A. Inspect the connection end and verify that the three Index Pins (21) are intact and in place. Verify that the three Collar Assy Lock Pins (19) are intact and in place and extended and engaging all three cutouts in the Collar Assy (8) and physically preventing Collar Assy (8) rotation. Check the Bearing Plate (42) containing the pins for possible cracks.

B. Hold the nozzle with the outlet or connecting end facing such that it can be observed. Apply pressure on the Collar Assy (8) in the direction to connect the nozzle aircraft, counterclockwise, to take up the slack and inspect the relative location of the three Lock Pins (19) with respect to the cutouts in the Collar Assy (8). The two Lock Pins (19) that are engaged in the normally wider cutouts should not be resting against the edge of their respective cutouts. If there is a space between these Index Pins (19) and the edge of the normally larger cutout, the collar is still in functional condition. If all three Lock Pins (19) are resting against the edge of their respective cutouts (there is no space), the Collar Assy (8) may no longer be in a functional condition and should be replaced if it fails the next step.

C. With the nozzle being held in the position described above, attempt to open the nozzle with the Lever (14). The nozzle should be prevented from opening by the interference between the Collar Assy (8) and the Lever (14). If the nozzle is openable, it should be removed from service and repaired.

D. Inspect the Lever (14) and the adjacent ramp surface of the Collar Assy (8) and verify that neither part is damaged or has missing pieces that permit the Lever (14) to be rotated to the open position with the nozzle disengaged or that will allow the Collar Assy (8) to rotate to the disengaged position when the Lever (14) is open. Broken or missing parts can result in dangerous fuel spills while refueling aircraft.

E. Verify that the Lever (14) is in the fully closed (against internal mechanical stop) position. (This is necessary to assure that the linkage is over center so internal pressure can not force the poppet open during the Collar Assy (8) engagement).

4.3.3 NOZZLE INSPECTION PRIOR TO EACH OVERHAUL

Using Eaton S204451 three lug adapter flange (or any standard flange that is a separate loose part and not a part of some other adapter housing) open the nozzle being careful to drain all trapped fluid into a sump. Even if the ball valve or a dry-break disconnect is utilized, there will be a small quantity of trapped fuel in the nozzle.

Check to see if there is a Cotter Pin (16) installed through the slotted poppet and the hole in the shaft. The pin must be installed in the hole that is completely within the slotted area of the poppet and the hole that allows for proper poppet nose seal adjustment.

Check the Poppet (15) to see what condition the shroud is in. The shroud is a sheet metal part that is press fitted onto the poppet and is no longer considered necessary. If it is firmly in place leave it until the next overhaul. If it is loose remove it by disassembling the Cotter Pin (16). Reassemble the unit less the shroud, it is no longer needed. Using the poppet adjustment tool 64000, adjust the poppet in accordance with the appropriate instructions in this service manual.

Grasp the poppet with one hand and holding the nozzle with the other attempt to un-screw the poppet from the shaft. The poppet will move a slight amount taking up the slack between the slot in the poppet, the hole in the shaft and the cotter pin.

On newer nozzles (any received after January 2001) check that the wear ring on the inlet of the nozzle is in place and is not worn out.

If all is correct close the nozzle and remove the adapter flange. Put the nozzle back in service. This procedure should be followed at each overhaul of the unit.

4.3.4 AIRCRAFT ADAPTER INSPECTIONS

The following inspections of the aircraft adapter are recommended to be carried out at

each refueling operation to assure that one is connecting to a safe adapter:

A. Visually check for bent, broken, missing or excessively worn lugs or slots. Worn slots are easily detected. A normal slot will have a slight machine broken edge (chamfer of .030 inch (0.762 mm)). If the edge is worn such that the corner is badly distorted and enlarged it should be inspected more closely and accurately. Carter Adapter Wear Gauge, 61657-2, should be utilized to check the width and thickness of the lugs if they appear to be worn. Wear of the thickness dimension of the lug will promote premature nose seal leakage. Wear of the width of the lug combines with slot wear in defeating the nozzle interlock.

B. Visually check the three slots for excessive wear. Excessive wear can permit disengagement of a nozzle without release of the three Collar Assy Lock Pins (19) and may permit accidental poppet opening on the disconnected nozzle. The use of Carter Gauge 61657-2 will provide a "no-go" check for the slots.

C. If any of the above conditions are observed, and or the gauge proves the adapter to be defective, the refueling operation should be continued only with extreme caution. The nozzle, upon disconnection, should be checked in accordance with paragraph 4.3.1.A.

5.0 **SPECIAL TOOLS**

The following special tools are recommended for proper repair and or overhaul of the nozzle:

- S204451 – Standard three lug bayonet adapter flange or equivalent.
- 6958CG or 6958CH Adapter or equivalent.

- 61657-2 Adapter Wear Gauge
- 64000 Poppet Adjustment Gauge
- 61607 Ball (10 & 11) Assembly Tool
- WL4680 Torque Wrench Kit

The above items are available from your Eaton Carter brand distributor.

6.0 **DISASSEMBLY**

6.1 Remove nozzle from end of hose at quick disconnect. Refer to appropriate service manual depending upon type of swivel disconnect utilized.

- SM61154Dry Break QD
- SM64015Ball Valve
- SM349MISCMiscellaneous
Adapters/Universal Inlet
- SM4067960427 type QD
- SM64019Unisex Coupling
- SM64020Unisex Coupling
- SM64031Unisex Coupling
- SM64254Low DP DB QD

discard the screw and replace it with a new one during reassembly. If Ball Assy Tool 61607 is available, screw it into the boss from which Screw (23) was removed. Hold the nozzle such that the Tool is below the nozzle and rotate the Quick Disconnect Adapter (49, 50, 56, 59, or 64), Ball Valve (62) or Regulator (47) until all Balls (11) have been captured in the Tool. The correct amount of Balls (11) will be captured when the level of Balls (11) reaches the line scribed on the tube of the Tool. If the Tool is not utilized, remove Balls (11), 39 each, from Unit by hand. Hold bolt hole vertical (pointed down) and allow all ball bearings to fall through the bolt hole. Catch all balls in a container. Some rotation between the Body (9) and the attached Adapter, Ball Valve or Regulator may be required to allow 39 Balls (11) to fall out of hole. Remove the Adapter, Ball Valve or Regulator (refer to appropriate Service Manual). If Clip (12) is to be replaced, use a pair of needle nose pliers to grasp the existing part and pull it from the hole in the Body (9). See Figure 5. Clear the hole of any debris.

6.2 Screw (23) is a self-locking type screw that utilizes a nylon insert in the threads to affect the resistance required to provide the locking. They are designed to be reused several times before losing their locking effectivity. Note: later version of the nozzle may incorporate a Screw (23) that has a recessed Allen key head instead of a screw driver slot. In addition the O-ring (24) used on the newer Screw (23) is smaller in diameter. It is important that the correct O-ring (24) is used with the correct Screw (23). The older Screw (23) [one with a screwdriver head is larger in diameter and the O-ring fits in the groove under the head of the Screw (23), while the one with the Allen head is smaller and the O-ring fits in a groove machined in the threaded body of the Screw (23)]. Using a torque wrench, remove Screw (23) and O-ring (24) from lower half of Body (9), measuring the torque during removal. If the torque is less than 9.5 in lbs (0.11 m kg)

Remove O-ring (25) from internal groove in the inlet of the Body (9). Visually inspect Wear Ring (9A) installed in the internal groove for excessive wear. If it appears to be worn remove for further inspection in section 7.0.

6.3

To remove the Cover (1) it is necessary to remove the appropriate Grips (4) or (6) or the appropriate Handle (8A). If the Cover (1) is in good condition it is not necessary to remove it at this time. Leave it attached to the handle.

- The Screw (4B) should be removed with a torque wrench and the removal torque measured. This screw is a self-locking type and is designed to be reused several times before losing its locking capability. If the torque is less than 6.5 in-lbs discard it and replace it during reassembly.
- Remove the Bumper (5) only if replacement is necessary by cutting through it.
- 6.4 Screw (7) is a self locking type screw that utilizes a nylon insert in the threads to affect the resistance required to provide the locking. Self locking screws are designed to be reused several times before losing their locking effectivity. Note that here again, the older units use the Screw (7) with a screwdriver slot and newer units use one with an Allen head. These Screws (7) are fully interchangeable. Using a torque wrench, remove Screw (7) from Collar Assy (8), measuring the torque during removal. If the torque is less than 9.5 in lbs (0.11 m kg) discard the screw and replace it with a new one during reassembly. Remove the Balls (10) from the bolt hole in the manner described in paragraph 6.2 above. There are 49 balls in this joint. The correct number of Balls (10) will be removed when the level in the Tool reaches the line created by the brass fitting that screws into the Collar (8). If the Tool is not utilized, store the Balls (10) in a separate container for cleaning and replacement later.
- 6.5 Engage the nozzle to the S204451 flange (any standard aircraft three-lug locking flange).
- 6.6 Remove Collar Assy (8) from Body (9) by aligning the groove in the Collar Assy (8) with detent on Body (9) and pull Body (9) from Collar Assy.
- 6.7 Remove S204451 Adapter.
- 6.8 Turn Lever (14) to open Poppet (15).
- 6.9 Remove Cotter Pin (16) and unscrew the Poppet Assy (15) from the Shaft (32). Older nozzles had a flow diverting shroud present that was pressed into place. If it is present and firmly in place, leave it in place. If it is loose, remove it completely and discard it. It is no longer needed. Refer to Figure 6 for location and identification of the shroud.
- 6.10 The Nozzle Seal Assembly (40) may be removed by lifting off Body (9). The Plate (42) may be removed from the Seal (41) by spreading the ends of the Retaining Ring (43), removing it from the groove in the Seal (41) and then sliding the Plate (42) off the Seal (41).
- 6.11 The three Lock Pins (19), three Lock Pin Springs (20), three Index Pins (21) and O-ring (18) may now be removed.
- 6.12 Hold the nozzle outlet in an “up” position as you would if the aircraft adapter were underwing. View Lever (14) to determine the age of the lever. Two older versions, both gray in color, were produced, one with an operating lever that is clocked in the 6 o'clock position when closed and the other with the handle clocked in the 3 o'clock position when closed. The newer lever is black, clocked at 6 o'clock and is retained by a single screw through the middle of the lever. Note: If a gray handle retained by a single screw is present replace it with a new black handle. Proceed to 6.12.1 if the older handles are present, otherwise proceed to 6.13.
- 6.12.1 If either older lever is present, hold the Body (9) with the outlet in an upward position. Rotate it until the two pipe Plugs (22) are visible. Remove the left hand plug. If the newer black lever is present move on to 6.13.
- 6.12.2 Remove Screws (35) through plug opening using a torque wrench. The torque to remove the Screws (35) shall not be less than 1.5 in.-lbs. If it is less than that discard and replace the Screws (35). Observe the orientation of the Plate (36) with respect to the Lever (14) such that it can be duplicated during reassembly. Misorientation will result in not being able to close the nozzle properly.
- 6.12.3 Remove Lever (14) from Body (9). Remove Seal (37) and Backup Ring (38) from Lever (14). Discard Seal (37) and Backup Ring (38). For more information regarding the three levers used on the nozzle see Service Bulletin SB3480801A available from Carter or your Carter distributor. Proceed to 6.15.
- 6.13 On nozzles with a black colored handle, serial number 6520 and subsequent, the handle is retained by a single screw located through the center of the Lever (14). There is no need to remove either of the Plugs (22) unless a leak has been observed. Proceed to 6.14 if the black handle is present.
- 6.14 Remove Screw (39), Washer (40) and O-ring (41) from the center of the Lever (14). Discard Screw (39) and O-ring (41). Pull Lever (14) from Body (9). Remove Seal (37) and Backup Ring (38) from Lever (14). Discard Seal (37) and Backup Ring (38). Proceed to 6.15.
- 6.15 On nozzles with older handles proceed to 6.15.1. On nozzles with the newer handles skip to 6.15.2.
- 6.15.1 Remove assembled Shaft (32), Pin (33), Link (34) and Plate (36) with attaching parts from Body (9). Remove Pin (33). Disassemble Cotter Pin (29), Nut (30) and Crank Pin (31) only if replacement is necessary. (Note that older links will be red in color while the newer ones will be natural stainless steel. Both are accept-able for use.)

- 6.15.2 Remove assembled Shaft (32), Pin (33), Link (34) and Crank (36) with attaching parts from Body (9). Disassemble Cotter Pin (29), Nut (30), Crank Pin (29), Wave Washers (35) from Link (34) and Crank (36). Discard Wave Washers (35)
- 6.16 Do not remove Cable (44) or (66), option D or Y only, unless replacement is required. The

mounting screw is included with the new replacement assembly.

- 6.17 On option E – remove the Vacuum Breaker (53) only if replacement is required. The Vacuum Breaker (53) is not economical to repair and should be replaced, if needed, as a complete assembly. **Attempts to repair this unit may result in fuel spills.**

7.0 **INSPECTION**

It is recommended that all O-rings (18), (24), (37) and (25), Back-up (38), Nose Seal (43), Wave Washers (35) & Cotter Pins (16) & (29) (if it is disassembled) be replaced upon every overhaul. Note: Be sure to order the correct O-ring (24) for the Screw (23) present. If a kit is being used, it will contain both O-rings (24), use the appropriate one and discard the other. Inspect all metal parts for dings, gouges, abrasions, etc. Use 320 grit paper to smooth and remove sharp edges. Replace any part with damage exceeding 15% of local wall thickness. Use alodine 1200 to touch up bared aluminum. Precisely measure the following items. Replace any part that exceeds the identified maximum or minimum wear limits:

- Both holes in item 34 Link (.196 inch (4.98 mm) diameter max. & .320 inch (8.13 mm) diameter max.).
- Bearing diameter of item 31 Pin (.300 inch (7.62 mm) diameter min).
- Tapered bearing diameter of item 14 Leer (.697 inch (17.7 mm) diameter min on large end & .635 inch (16.1 mm) diameter min on small end).
- Measure diameter of the three round holes in Plate (42). If holes are elongated or exceed 0.222 inches (5.639 mm) the Plate (42) should be replaced. Measure the width and diameter of the other three holes. If the diameter exceeds 0.330 (8.382 mm) or the width across the flats exceeds 0.253 inches (6.426 mm), the Plate (42) should be replaced.

On older nozzles without a wear ring in the body, check the ball race [internal groove that mates the Balls (10)] inside the Body (9) for raised burrs or buildup of material that may prevent the disassembly of the mating Adapter. The corner of the ball race should be a smooth radius no greater than .03 inches (.76 mm). The raised burr may be removed with appropriate abrasive. If it is too large to remove in this manner, replace the body.

On newer nozzles with the wear ring in the body, if worn remove for inspection. Measure the smallest diameter and if less than 0.075 replace it.

Check the ball race located inside the Collar Assy (8) for raised burrs in the same manner as above.

Check the external ball race on the large OD of the Body (9) in the same manner as above.

Roll Pin (21) on a flat surface to check for straightness. Replace any suspect pin.

Examine the Lever (14) for cracks. On newer nozzles, also examine the fit between the Lever (14) "teeth" and the Crank (36) "teeth" by placing the two parts together and attempting to rotate them against each other. The fit should be snug and not loose. Replace both parts if looseness appears to be present. **Do not replace only one part.**

8.0 **REASSEMBLY**

- 8.1 Reassemble in reverse order of disassembly (Refer to Figure 2 or 3 depending upon the version of nozzle), observing the following:
 - 8.1.1 Make certain all components are clean and free from oil, grease, or any other corrosion resistant compound on all interior or exterior surfaces. Wash all parts with cleaning solvent and dry thoroughly with a clean, lint-free cloth or compressed air.

WARNING:
Use cleaning solvent in a well-ventilated area. Avoid breathing of fumes and excessive solvent contact with skin. Keep away from open flame

DO NOT use any form of grease on Balls (10) or (11) and be certain to install proper number of balls in each hole of Body (9) and collar assembly. The use of Tool 61607 will facilitate the counting and assembly of the Balls (10 or 11) back into the unit. Also make sure that Clip (12) is installed properly to maintain continuity

through the unit. Refer to Figure 5 for installation information.

NOTE: A light coat of petroleum jelly can be applied to all O-rings, springs, and screws for ease of installation.

8.1.2 If Cotter (29) and Nut (30) were removed during disassembly, torque Nut (30) to 80 – 125 in lbs to align slots in nut with hole in Crank Pin (31). When reinserting the sub-assembled parts noted in Para. 6.16 of the disassembly procedure, through the inlet end of the Body (9), ensure that the Shaft (32) is inserted into the Body's (9) axial guide bore far enough that the bore contains the Dowel Pin (33).

On nozzles with the older levers (Figure 3), assure that the orientation of the Plate (36) to the Lever (14) is as observed prior to disassembly. Wave Washers (42) are not used on these nozzles with Plate (36). Use the 9/64 inch Allen wrench through the Body's (9) pipe thread port to secure the Plate (36) to the end of the Lever (14) shaft with the four socket head Screws (35). Torque each of the Screws (35) to 16 to 18 inch pounds above the torque required to rotate the screws in the thread locking inserts installed in the Lever (14) end.

Reinstall the Plug (22). NOTE: Plug (22) when purchased from Carter includes a sealant and the use of Teflon tape is not required. If new Teflon tape is used on reinstallation do not utilize more than 1 ½ wraps of tape. Excessive use of tape could lead to the cracking of the Body (9).

On nozzles with the newer levers the orientation of the Crank (36) is not critical at this point since it will be aligned with the Lever (14). Install Backup Ring (37) and O-ring (38) onto Lever (14) and insert into Body (9). Lever (14) should be aligned with Crank (36) to result in the Lever (14) being at the 9 o'clock position when in the closed position (3 o'clock when opened). The "teeth" in both parts should mesh during the assembly. Place Washer (40), O-ring (41) onto Screw (39) and insert into hole in center of Lever (14). Torque the Screw (39) in the outer portion of the Lever (14) to 125 ± 5 inch pounds, loosen the Screw (39) and retorque to 125 ± 5 inch pounds.

8.1.3 Should it be desired to be able to change the nose seal of the nozzle without a major disassembly of the unit it is possible to do so by eliminating Snap Ring (43). One word of caution should this be done. If the nozzle is opened with a tool that does not have the

characteristic lugs of an adapter, the nose seal may follow the poppet open and be difficult to reinstall without disassembly. The Snap Ring (43) will continue to be installed by the factory.

8.1.4 Connect nozzle to S204451 flange when installing the Poppet (15). Use the Lever (14) and move the Shaft (32) to its fully extended (open) position to install the Poppet Assy (15).

Before inserting the Cotter (26), adjust the Poppet Assy (15) using the following instructions:

Use Poppet Adjustment Gauge, 64000, to facilitate the adjustment of the Poppet (15) onto the Shaft (32). Follow instructions furnished with the gauge. If the gauge is not used, place a straight edge across the center of the elastomer lip of the Seal (41). Use feeler gages to measure the average dimension between the bottom of the straight edge and the Poppet (15) face. This dimension should be .070 to .110 inch (1.8 to 2.8 mm). If it is not, calculate the required poppet dimension as follows: (one quarter (1/4) turn of the Poppet (15) axially displaces the Poppet (15) face about .020 inch (0.51 mm).

A. If the feeler gage measurement is too long, prepare to unscrew (loosen) the Poppet (15) one quarter (1/4) turn for each .020 (0.51 mm) inch of required adjustment.

B. If the measurement is too short, prepare to tighten the Poppet (15) one quarter (1/4) turn for each .020 (0.51 mm) inch of required adjustment.

8.15 Once the proper Poppet Assy (15) adjustment is made, rotate the Poppet toward the tightening direction until the next slot in the Poppet Assy (15) is in line with the hole in the Shaft (32). Insert the Cotter (26) and bend over the ends to retain in place in accordance with Figure 6. Note it is important that the correct length of Cotter Pin (16) is utilized for the assembly.

8.2 If the Grip (4) or (6) requires replacing due to wear or the replacement of the Cover (1), the new Grips (4) or (6) shall be reinstalled.

8.3 If Bumper (5) is to be replaced onto Collar Assy (8) warm Bumper (5) in water at 160-180° F to soften before pressing onto Collar Assy (8) .

8.4 If stick Handles (8A) were removed for replacement they should be reassembled to Collar (8) using the appropriate Screws (8B), Washers (8C) and Nuts (8D). Tighten to secure Handles (8A) into place in the Collar (8).

9.0 **TEST**

9.1 The following test procedures will be accomplished after overhaul:

9.2 Test conditions

Test media shall JP-4, Jet A or odorless kerosene, commercial solvent 140.

9.3 Functional Test

9.3.1 The nozzle shall be inserted and locked into a test adapter, Carter 6958CG or CH or equivalent and the nozzle valve actuated by use of the crank Lever (14) from the fully closed to fully open position a minimum of five times. There shall be no evidence of binding or excessive force required for valve actuation.

9.4 Leakage Test

9.4.1 With the nozzle outlet in the normal open position, and the test adapter outlet closed, pressurize the inlet to five PSIG and hold for one minute minimum. There shall be no evidence of external leakage from the nozzle.

9.4.2 Repeat the leakage test at 60 PSIG and 120 PSIG.

9.4.3 Close and disengage the nozzle and repeat 9.4.1 and 9.4.2.

10.0 ILLUSTRATED PARTS CATALOG

Table 1.0 tabulates the parts and sub-assemblies comprising the 64349 Pressure Fueling Nozzle. The item numbers of the table are keyed to the exploded views of the nozzle diagrammed in Figures 1 thru 6.

**TABLE 1
OPTIONS**

Fig. No.	Item	Part Number	Description	Used as Option
1,4	46	44311	Cable Assy	D
1	47	44646-*	Hose End Control Valve (Note 1)	F3, F4, F5
	48	44326	D-2 Flanged Inlet (Note 4)	J
	49	44327	D-1 Flanged Inlet (Note 4)	H
	50	44663	Adapter – 61154 (Note 7)	6
	51A	44373-**	Screen Assy (Note 6)	A, B, C
	51B	41767-**	Screen Assy (Note 6)	B,C
	51C	47115-**	Screen Assy (Note 6)	A, B, C
	51D	47307-100	Screen Assy (Note 6)	C
	52	43045-1	Adapter – Option 2 (Note 4)	2
	53	43108-*	QD, Female Half (Note 3)	9H, L, P
	54	44325	QD, 2" Female Camlock (Note 4)	K
	55	41599	Vacuum Breaker	E
	56	47063	MIL-C-24356 Inlet (Note 4)	W
	57	64349	Nozzle	All
	58	44697	Short Male Adapter Assy (Note 2)	7
	59	44701	Long Male Adapter Assy (Note 2)	8
	60	61154H	Dry Break Assy, 2½ NPT (Note 7)	7H
		61154L	Dry Break Assy, 3 NPT (Note 7)	7L
		61154P	Dry Break Assy, 2 NPT (Note 7)	7P
	61	64019N	2" Unisex coupling (Note 13)	X
	62	64015*	Ball Valve (Note 9)	3H, 3K, 3L, 3N,3 P
	63	64019NV	2" Unisex coupling (Green) (Note 13)	V
	64	44362	Male Adapter Assy (Note 4)	9
	65	44771	Female Half Inlet Assy (2:" Camlock)	S
	66	47028	Military Style Bonding Cable	Y
	67	64031H	3" Unisex Coupling (Tan) (Note 14)	M
	68	64020N	2" Valved Unisex Coupling (Tan) (Note 13)	5
	69	47566	Universal Inlet - D-1/D-2	N
	70	47633	Military Male Half Assembly – Low DP DB (Note 8) ..	6Y
	71	47584-1	Female Half Assembly – Low DP DB – 2" NPT ..	6P
	72	47854-2	Female Half Assembly – Low DP DB – 2 1/2" NPT	6H
	73	47584-3	Female Half Assembly – Low DP DB – 3" NPT	6L
	74***	210641	Safety Ring	6YPX, 6YHX, 6YLX

*** Safety Clip (P/N 210641) for the 61154 Drybreak QD is considered FOD (Foreign Object Damage) and not included on military nozzle assemblies; however, it can be added as a no cost option.

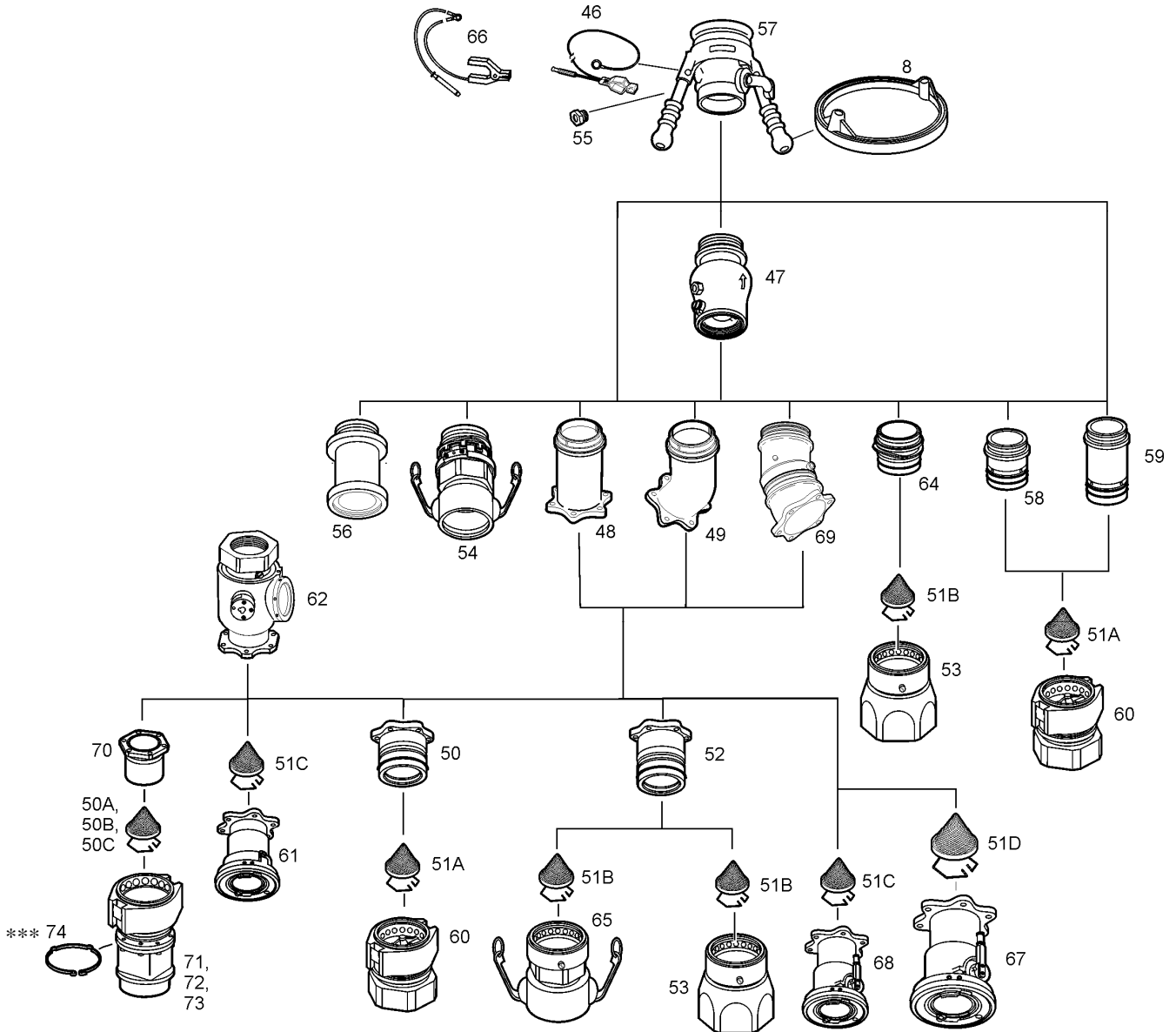

*** Item 74 Safety Clip (P/N 210641) for the 61154 Drybreak QD is considered FOD (Foreign Object Damage) and not included on military nozzle assemblies; however, it can be added as a no cost option.

FIGURE 1
CHART OF OPTIONS AVAILABLE

TABLE 2.0
Current Production Version

Fig. No.	Item	Part Number	Description	Units/ Assy	Nozzle Option	NSN
2	1	207799	Cover.....	1	All	5340-01-246-2706
	2-3	Left intentionally blank				
1, 4	4	207808	Grip	2	All but U	5340-01-324-0954
	4A	GF960-516	Washer.....	2	All	5310-00-167-0820
2	4B	GF16997-78L	Cap Screw	2	All	5305-01-189-3761
	5	23622	Bumper	1	All	4930-00-848-1310
1, 4	6	207816	Circular Handle	1	U	
	7	220484	Screw, Pan Head (Note 10).....	1	All	5305-01-246-3868
2	8	220269	Collar.....	1	All	4930-01-385-9453
	8A	210600	Handle	2	All	5340-01-415-1292
2	8B	GF4-13A	Screw.....	2	All	
	8C	GF960-416	Washer.....	2	All	
2	8D	GF21042-4	Nut	2	All	
	9	207784	Body (Replaced by 47375).....	1	All	Use 47375
2		47375	Body Assembly (on newer nozzles)	1	All	
		221341	Body (not available as a spare part - order 47375 only)	1	All	
2	9A	220893	Wear Ring (newer nozzles) (Note 8)	1	All	
	10	221075	Bearing, Ball	49	All	3110-01-247-1056
2	11	221075	Bearing, Ball	39	All	3110-01-247-1056
	12	209853	Clip.....	1	All	
2	13	Left intentionally blank				
	14	220878-1	On/Off Act. Lever (New Lever) (Note 11).....	1	All	
2	15	210593	Poppet.....	1	All	4820-01-252-3725
	16	GF24665-302	Pin, Cotter	1	All	5315-00-234-1864
2	17	Left intentionally blank				
	18	M25988/1-145	O-ring.....	1	All	5330-01-010-2419
2	19	220272	Pin, Collar Lock.....	3	All	5315-01-385-5535
	20	20909	Spring, Collar Lock Pin	3	All	5360-00-155-5099
2	21	24780	Pin, Indexing	3	All	4930-01-053-0194
	22	210388	Plug.....	2	All	4730-01-198-9551
2	23	220484	Screw, Pan Head.....	1	All	5305-01-246-3868
	24	MS29512-03	O-ring (Note 10).....	1	All	
2	25	M25988/1-235	O-ring.....	1	All	5330-01-007-4899
	26-28	Left intentionally blank				
2	29	GF24665-1013	Pin, Cotter	1	All	5315-01-025-4510
	30	GF320C4	Nut, Castellated	1	All	5310-00-721-4434
2	31	220886	Pin, Crank (Note 11).....	1	All	
	32	210368	Shaft	1	All	3040-01-385-8986
2	33	D9-437	Dowel Pin.....	1	All	5315-01-341-8766
	34	207795	Link	1	All	
2	35	5806-21-3	Wave Washer (Note 11).....	2	All	
	36	220878-3	Crank (Note 11)	1	All	
2	37	207792	O-ring, TFE Coated	1	All	5330-01-246-7351
	38	MS28774-017	Back-up.....	1	All	5330-00-833-4210
2	39	GF16997-69	Screw (Note 11).....	1	All	
	40	5710-54-60	Washer (Note 11)	1	All	
2	41	MS29513-010	O-ring (Note 11).....	1	All	
	42	47058	Nose, Seal Assy	1	All	4930-01-385-9488
2	43	209029	Seal, Nozzle	1	All	5330-01-264-0134
	44	220271	Plate, Bearing.....	1	All	3110-01-385-3438
2	45	24636	Ring, Snap.....	1	All	5340-01-053-0192

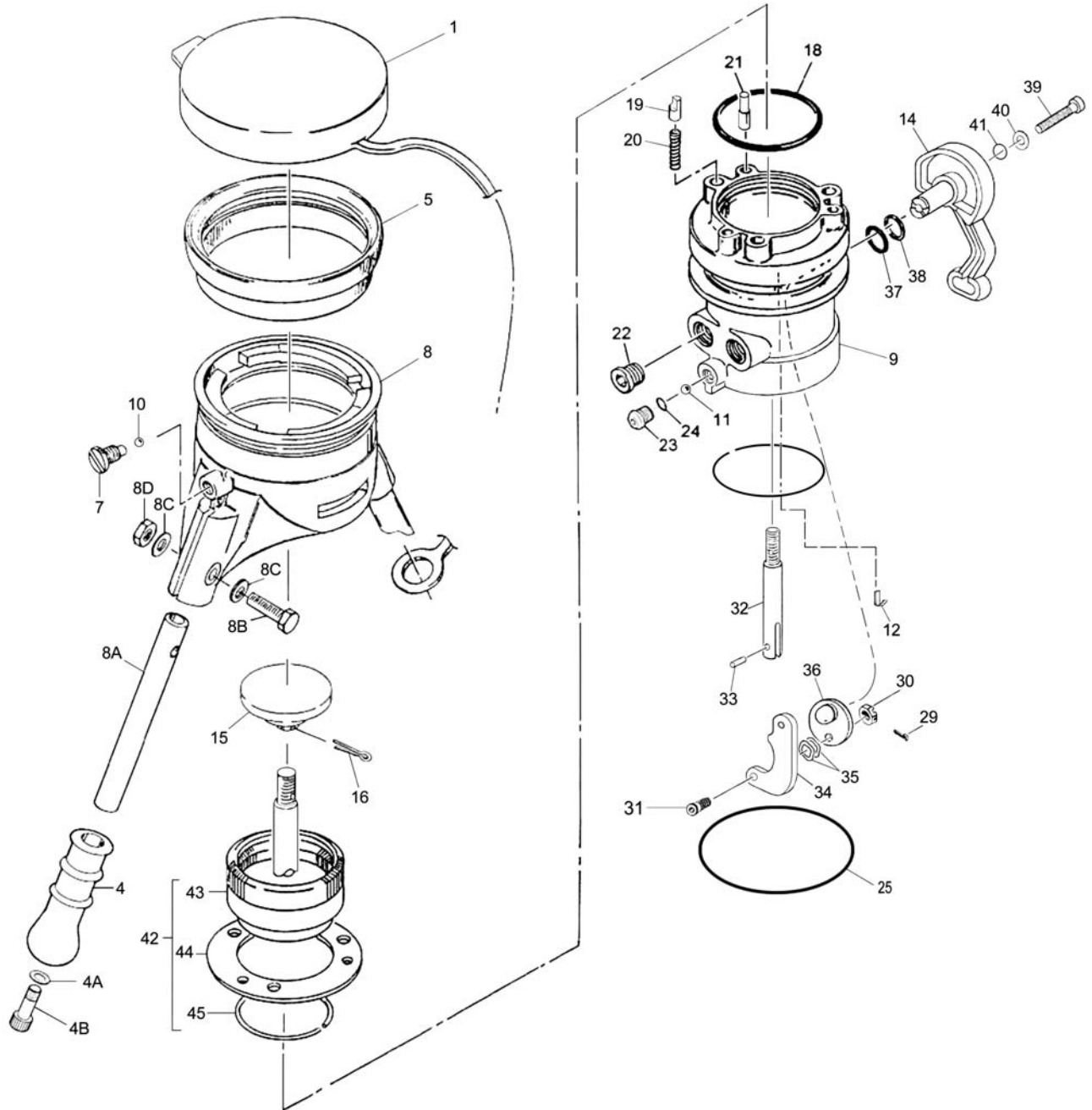
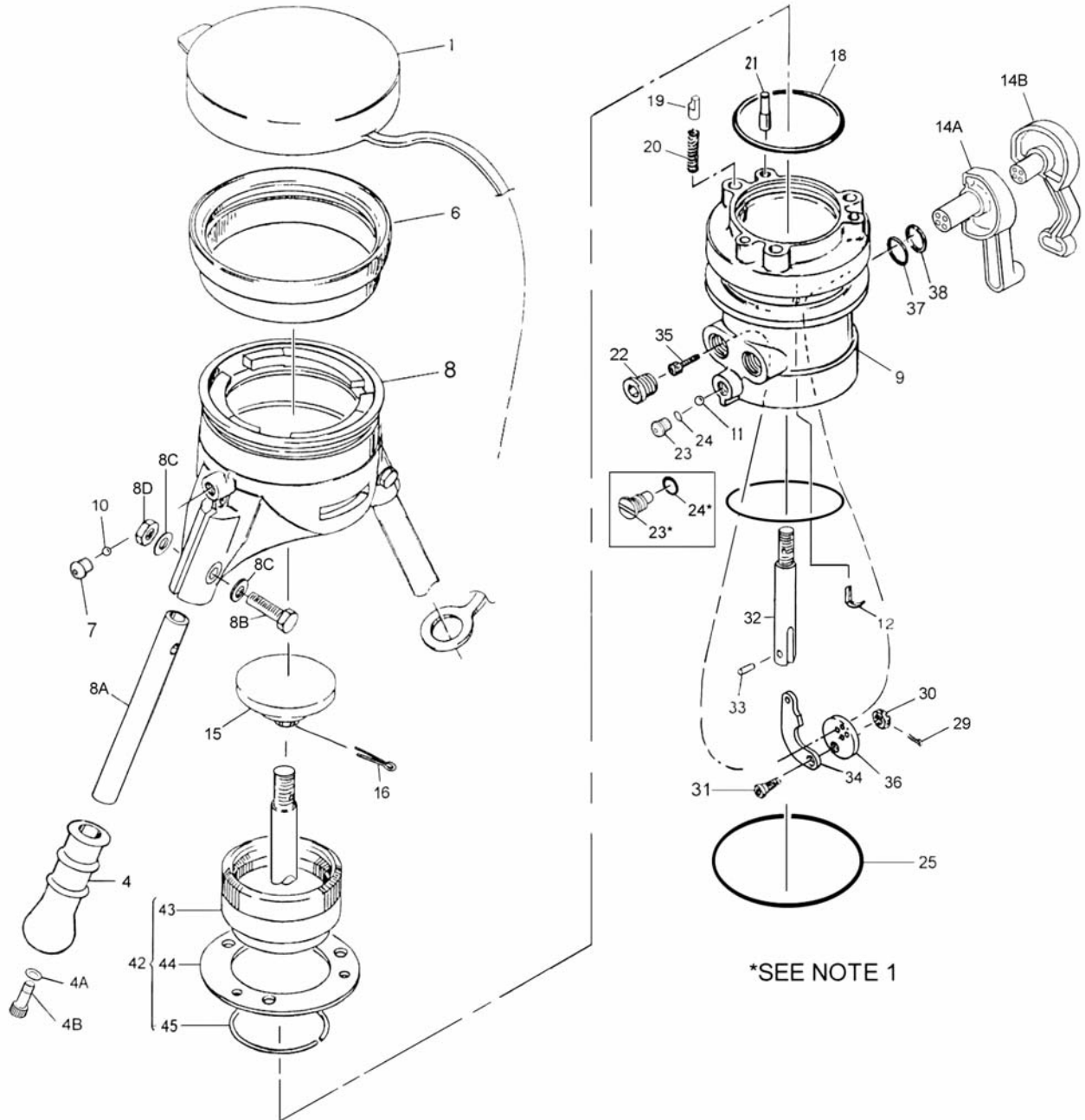

FIGURE 2
CURRENT PRODUCTION CONFIGURATION

Table 3
Previous Configuration Nozzle

Fig. No.	Item	Part Number	Description	Units/ Assy	Nozzle Option	NSN
3	3		Left intentionally blank			
	4	207808	Grip	2	All but U	5340-01-324-0954
	4B	GF16997-78L	Cap Screw	2	All	5310-00-167-0820
	4A	GF960-416	Washer	2	All	5305-01-189-3761
	5	23622	Bumper	1	All	4930-00-848-1310
1, 4	6	207816	Circular Handle	1	U	
3	7	220484	Screw, Pan Head (Note 10).....	1	All later units	5305-01-246-3868
		209827	Screw, Cap (Note 10)	1	All older units	
	8	220269	Collar	1	All	4930-01-385-9453
	8A	210600	Handle	2	All	5340-01-415-1292
	8B	GF4-13A	Screw	2	All	
	8C	GF960-416	Washer	2	All	
	8D	GF21042-4	Nut	2	All	
	9	207784	Body (Replaced by 47375)	1	All	4930-01-244-8043
		47375	Body Assembly (on newer nozzles)	1	All	
		221341	Body (not available as a spare part - order 47375 only).....	1	All	
	9A	220893	Wear Ring (newer nozzles) (Note 8)	1	All	
	10	221075	Bearing, Ball	49	All	3110-01-247-1056
	11	221075	Bearing, Ball	39	All	3110-01-247-1056
	12	209853	Clip.....	1	All	
	13		Left intentionally blank			
	14A	220270	On/Off Act. Lever (Old Lever) (Note 11)...	1	All older units	3040-01-385-9064
	14B	220561	On/Off Act. Lever (Old Lever) (Note 11)	1	All newer units	
	15	210593	Poppet	1	All	4820-01-252-3725
	16	GF24665-302	Pin, Cotter	1	All	5315-00-234-1864
	17		Left intentionally blank			
	18	M25988/1-145	O-ring	1	All	5330-01-010-2419
	19	220272	Pin, Collar Lock.....	3	All	5315-01-385-5535
	20	20909	Spring, Collar Lock Pin	3	All	5360-00-155-5099
	21	24780	Pin, Indexing	3	All	4930-01-053-0194
	22	210388	Plug.....	2	All	4730-01-198-9551
	23	220484	Screw, Pan Head.....	1	All newer units	5305-01-246-3868
		209827	Screw, Cap (Note 10)	1	All older units	
	24	MS29512-03	O-ring (Note 10).....	1	All newer units	
		MS29513-013	O-ring (Note10).....	1	All older units	5330-00-248-3828
	25	M25988/1-235	O-ring	1	All	5330-01-007-4899
	26-28		Left intentionally blank			
	29	GF24665-1013	Pin, Cotter	1	All	5315-01-025-4510
	30	GF320C4	Nut, Castellated	1	All	5310-00-721-4434
	31	207788	Pin (Note 11).....	1	All	
	32	210368	Shaft	1	All	3040-01-385-8986
	33	D9-437	Dowel Pin.....	1	All	5315-01-341-8766
	34	207795	Link	1	All	
	36	LP65U82J12M	Screw	4	All newer units	5305-01-413-0746
		GF16995-28	Screw (Note 11).....	4	All older units	
	37	207792	O-ring, TFE Coated	1	All	5330-01-246-7351
	38	MS28774-017	Back-up.....	1	All	5330-00-833-4210
	42	47058	Nose, Seal Assy	1	All	4930-01-385-9488
	43	209029	Seal, Nozzle	1	All	5330-01-264-0134
	44	220271	Plate, Bearing.....	1	All	3110-01-385-3438
	45	24636	Ring, Snap	1	All	5340-01-053-0192



*SEE NOTE 1

**FIGURE 3
PREVIOUS CONFIGURATION**

Note: 1. Previous configuration nozzles can be updated to the current production configuration by using KD64349-12 Kit on overhaul.

**Table 4
Repair Kit Information**

Kit Part Number	Description	Kit Contents	NSN
KD64349-1	Kit Maintenance – Soft goods for normal overhaul of basic 64349	Items 7, 12, 16, 18, 23, 24, 25, 29, 37, 38, 39, 41, 43, M25988/1-040 O-ring, M25988/1-235 O-ring & 207807 Seal	4930-01-385-9025 (Note 12)
KD64349-2	Kit to make a major overhaul when used with a –1 kit.	Items 1, 4, 5, 14, 15, 19, 20, 21, 31, 35, 36, 39, 40 & 41	4930-01-385-9083 (Note 12)
KD64348-12	Converts one-piece lever to two-piece design.	Items 14, 24, 29, 31, 35 and 36-41.	(Note 12)
KD64201-3	Kit to overhaul the 64254 Dry Break.	-	-

Notes:

1. Refer to SM44646, as appropriate, for detail information. *Add pressure rating to part number to complete it.
2. Refer to SM61154, SM40679, SM64254 or SM64015 for detail information.
3. Refer to SM40679 for detail information.
4. Refer to SM349MISC for detail information.
5. All part numbers beginning with "GF" are interchangeable with those beginning with either "AN" or "MS". If the "GF" is followed by three numbers it is interchangeable with and "AN" part, otherwise it is interchangeable with an "MS" part of the same number.
6. Refer to SM44315, SM61154, SM40679, SM64015 or SM64020 for detail information. **Add screen mesh size to part number to complete it. Only 100-mesh screen available on Option M.
7. Refer to SM61154 or SM64001 for detail information.
8. Item 9A is not present on older nozzles.
9. Refer to SM64015 for detail information.
10. The MS29512-03 Gasket (24) is used with Screw (23) 220484. This is available as an assembly (and is more economical to order as such) as part number KDT-1191. If Screw (23) 209827 is to be replaced do so with KDT-1191. O-ring (24) MS29513-013 is used with the older Screw (23) 209827 only.
11. There have been three item 14 On/Off Actuating Levers used on the 64349 Nozzle. Item 14, replaces the previously used items 14A and 14B. Several other parts are needed to replace (14A) or (14B) and are furnished with KD64349-2 and KD64348-12. Neither (14A) or (14B) are available, they will automatically be replaced by KD64349-12. Wave Washer (35) is used to provide friction in the lever mechanism to keep the lever in the open position during flow conditions.
12. Contents of these kits have changed in the past year hence kits in the stock system may be different than the contents listed.
13. Refer to SM64019 for detail information.
14. Refer to SM64031 for detail information.

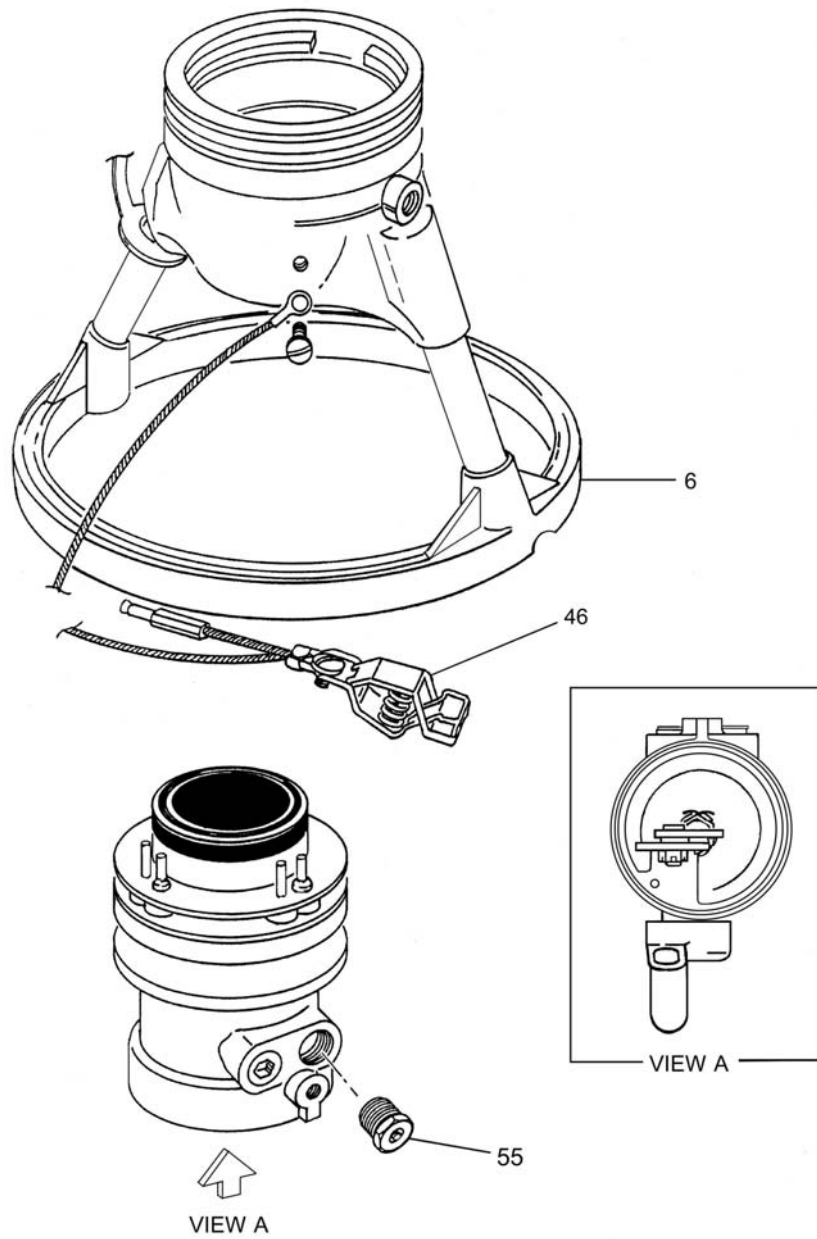

**FIGURE 4
ADDITIONAL OPTIONS**

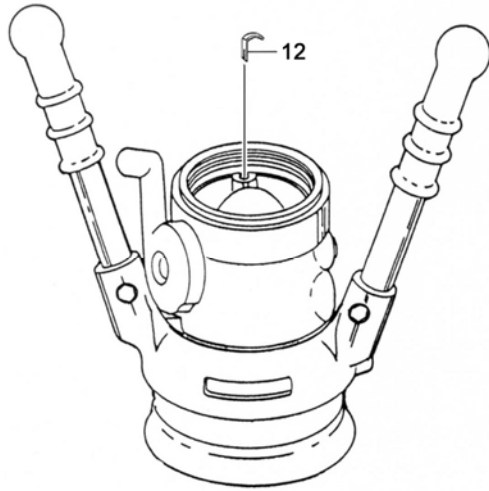

FIG. 5A
CONTINUITY CLIP INSTALLATION (12)

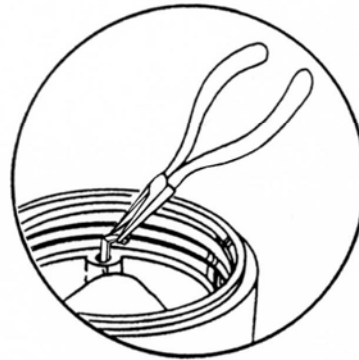
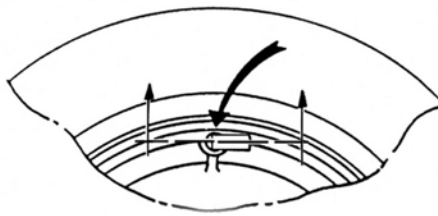

FIG. 5B
REMOVING CLIP (12)



OVERHEAD VIEW

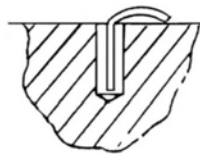
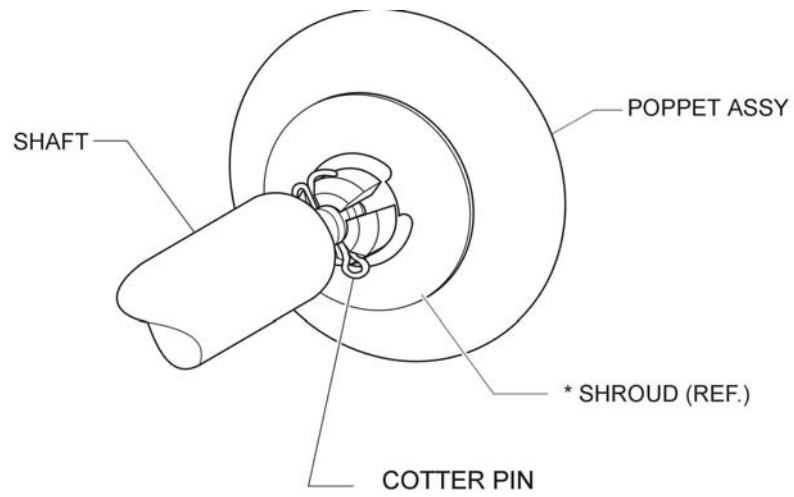

FIG. 5C
CORRECT CLIP INSTALLATION (12)

**FIGURE 5
CONTINUITY CLIP INSTALLATION**



* Not on newer models
(no longer needed).

FIGURE 6
POPPET-SHAFT RETENTION

11.0 FAILURE MODES AND EFFECTS ANALYSIS

11.1 Notes that apply to this analysis:

- A. Hazard category, hazard probability, and real hazard index (RHI) are defined herein.
- B. "Visual inspection" means examining the nozzle for obvious cracks, damage, and broken lugs, prior to initial pressurization.
- C. "Pressure test prior to use" means pressurizing the nozzle and attached hose to operating fuel pressure, then removing pressure, prior to aircraft arrival.
- D. "Shut off fuel at source" will be the first action for any leak. To further improve operating safety, this procedure should be used for all refueling operations. In addition, fuel flow should be turned on at the source, not at the nozzle.
- E. Item numbers referred to in this section are those used in Figure 5.

11.2 RISK ASSESSMENT - A risk assessment procedure based upon the hazard probability, as well as hazard severity may be required to establish priorities for corrective action and resolution of identified hazards. One example is the real hazard index; a numeric rank ordering of a mathematical combination arrived at by assigning numerical values to the severity category and probability level.

A. Hazard Probability - The probability that a hazard will occur during the planned life expectancy of the system can be described in potential occurrences per unit of time, event, population, item or activity. Assigning a quantitative hazard is generally not possible early in the design process. A qualitative hazard probability may be derived from research, and evaluation of historical safety data from similar systems.

Level	Descriptive word	Specific Individual Item	Fleet or Inventory
A (6)	Frequent	Likely to occur frequently	Continuously experienced
B (5)	Reasonably probable	Will occur several times in life of an item	Will occur frequently
C (4)	Occasional	Likely to occur sometimes in the life of an item	Will occur several times
D (3)	Remote	So unlikely, it can be assumed that this hazard will not be experienced	Unlikely to occur but possible
E (2)	Extremely Improbable	Probability of occurrence cannot be distinguished from zero	So unlikely it can be assumed that this hazard will not be experienced
F (1)	Impossible	Physically impossible to occur	Physically impossible

B. Hazard Severity - Hazard severity categories are defined to provide a qualitative measure of the worst potential consequences resulting from personnel error, environmental conditions, design inadequacies, procedural deficiencies, or system, subsystem or component failure/ malfunction.

Severity Category	Descriptive word	Results
I (4)	Catastrophic	May cause death or system loss
II (3)	Critical	May cause severe injury, or system damage
III (2)	Marginal	May cause minor injury, minor occupational illness, or minor system damage
IV (1)	Negligible	Will not result in injury, occupational illness, or system damage

C. Real Hazard Index (RHI) Matrix - (RHI = Hazard Severity X Probability Level)

		<u>HAZARD SEVERITY</u>			
		<u>I (4)</u>	<u>II (3)</u>	<u>III (2)</u>	<u>IV (1)</u>
<u>PROBABILITY LEVEL</u>	A (6)	24	18	12	6
	B (5)	20	15	10	5
	C (4)	16	12	8	4
	D (3)	12	9	6	3
	E (2)	8	6	4	2
	F (1)	4	3	2	1

General guidelines for required action.
RHI

- 1-8 No action required.
- 9-12 Special precautions required, investigate redesign.
- 13-24 Hazardous, redesign necessary or procedural control if redesign is impractical.

11.3 FAILURE MODES AND EFFECTS ANALYSIS (FMEA) – Refer to Figure 5 for component numbers mentioned in column one.

NR	COMPONENT	FUNCTION	FAILURE MODE	RESULT OF FAIL	HAZARD CATEGORY	HAZARD PROBABILITY	REAL HAZARD INDEX (RHI)	CORRECTIVE ACTION
1	Bumper Ring (7)	Protects lug ring on collar	Missing or torn	Possible ring damage (no hazard)	IV (1)	4 (C)	4	Visual Inspection
2	Collar (10)	Secures nozzle to aircraft receptacle	Cracked or Broken	Difficulty in connecting to aircraft	IV (1)	3 (D)	3	
			Damaged Ball Grooves	Difficulty in connecting to aircraft	IV (1)	3 (D)	3	
			Cracked, worn or bent lugs	Improper seal resulting in fuel leak	II (3)	4 (C)	12	Visual Inspection
3	Collar retaining balls (49)	Retain nozzle collar to nozzle body	Broken or missing lug (s)	Nozzle released from aircraft receptacle resulting in fuel spill/spray	I (4)	3 (D)	12	Visual Inspection
			Broken or galled	Difficulty in connecting to aircraft	IV (1)	4 (C)	4	
			Missing (all)	Unit unusable	IV (1)	4 (C)	4	Visual Inspection
4	Retaining ball screw (9)	Provides access for collar retaining balls. Allows balls to move freely in raceway.	Missing (35-48)	Unit may not align; difficulty connecting to aircraft. Possible fuel leak.	II (3)	4 (C)	12	1) Pressure test prior to use 2) Visual Inspection
			Missing (34 or less)	No effect	IV (1)	4 (C)	4	
			Missing	Loss of retaining balls	II (3) or IV (1)	4 (C)	12 or 4	Depends on number of balls missing (see item #3)
			Loose	Possible loss of retaining balls	II (3) or IV (1)	3 (D)	9 or 3	Same as above, but less likely
5	Handle grip (2)	Provides gripping surface for handle	Missing or torn	None	IV (1)	4 (C)	4	
6	Handle Bolt (2)	Holds handle grip in place	Missing or loose	Handle separates	IV (1)	4 (C)	4	Use another handle
7	Handle Nut (2)	Holds handle grip in place	Missing or loose	Handle separates	IV (1)	4 (C)	4	
8	Body	Holds all components together	Cracked	1) Fuel leak	I (4)	3 (D)	12	1) Pressure test prior to use
				2) Difficulty in attaching to aircraft	IV (1)	3 (D)	3	2) Visual Inspection
9	Access Port Plug (2)	Provides access for applying pressure gauge or other accessories	Missing	Massive fuel spill	I (4)	3 (D)	12	Same as above
10	Handle	Rotates collar to attach or detach nozzle	Missing, bent or broken	Cannot attach nozzle	IV (1)	3 (D)	3	
11	Poppet Valve seal holder	Retains poppet valve seal	Missing or broken	Fuel spray	I (4)	3 (D)	12	Pressure test prior to use
12	Snap Ring	Holds flange onto poppet valve seal holder	Missing or broken	Poppet seal does not stay completely in place; minor fuel leak	II (3)	2 (E)	6	
				Poppet valve may be blocked from closing	II (3)	2 (E)	6	Shutoff fuel at source.. Aircraft poppet valve will prevent backflow

NR	COMPONENT	FUNCTION	FAILURE MODE	RESULT OF FAIL	HAZARD CATEGORY	HAZARD PROBABILITY	REAL HAZARD INDEX (RHI)	CORRECTIVE ACTION
13	Body O-Ring	Provides seal between body and valve seat assembly	Missing	Fuel Spray	I (4)	3 (D)	12	Pressure test prior to use
			Torn or broken	Fuel leak	II (3)	3 (D)	9	Same as above
14	Seal Flange	Attaches poppet valve seal to nozzle body	Cracked or loose	Fuel Spray	I (4)	3 (D)	12	Same as above
			Bent or warped	Improper poppet valve seal resulting in fuel spray	I (4)	3 (D)	12	Same as above
15	Poppet Valve Seal	Seals poppet valve in body	Torn or broken	Fuel Spray	I (4)	3 (D)	12	Same as above
16	Alignment Pin (3)	Provides proper alignment between nozzle and aircraft receptacle	Missing 1 or 2	None	IV (1)	3 (E)	3	
			Missing all 3	Difficulty attaching nozzle to aircraft	IV (1)	3 (E)	3	
17	Collar Lock Pin (3)	Prevents rotation of nozzle collar	Missing 1 or 2	None	IV (1)	3 (E)	3	
			Stuck retracted (1 or 2)	None	IV (1)	3 (E)	3	
			Missing all 3	Loss of nozzle collar interlock. Can flow fuel without nozzle attached to aircraft	I (4)	3 (D)	12	Procedural error also needed for fuel spill. Valve link has overcenter feature to prevent fuel pressure from opening valve
			Stuck retracted (All 3)	Same	I (4)	3 (D)	12	Same as above
			Stuck extended	Cannot attach nozzle to aircraft	IV (1)	3 (E)	3	
			Installed backwards or upside down	Cannot assemble nozzle	IV (1)	3 (E)	3	
18	Collar Lock Pin Spring (3)	Keeps collar lock pin extended	Missing or broken (1 or 2)	None	IV (1)	3 (E)	3	
			Missing or broken (All 3)	Loss of collar interlock (depending on orientation of aircraft receptacle) Can flow fuel without nozzle attached to aircraft	I (4)	3 (D)	12	Same as above
19	Swivel Inlet Tube	Attaches refueling hose to nozzle	Cracked or broken	Fuel spray or leak	I (4)	3 (D)	12	Pre-use visual inspection
20	Swivel Bearing	Keeps swivel inlet tube properly aligned	Missing or broken	Difficulty in attaching nozzle to aircraft	IV (1)	3 (E)	3	
21	Retaining Balls (39)	Keeps swivel inlet tube attached to nozzle	Broken or galled	Difficulty in attaching nozzle to aircraft	IV (1)	3 (E)	3	
			Missing (All)	Unit unusable; swivel tube won't stay attached	IV (1)	3 (E)	3	
			Missing (25-33)	Fuel leak	II (3)	4 (C)	12	Pressure test prior to use
			Missing (24 or Less)	None	IV (1)	4 (C)	4	
22	Retaining Ball Screw	Provides access for swivel retaining balls. Allows balls to move freely in raceway	Missing	Loss of retaining balls	II (3) IV (1)	4 (C)	12 4	Depends on number of balls missing (See item #21)

NR	COMPONENT	FUNCTION	FAILURE MODE	RESULT OF FAIL	HAZARD CATEGORY	HAZARD PROBABILITY	REAL HAZARD INDEX (RHI)	CORRECTIVE ACTION
			Loose	Possible loss of retaining balls	II (3)	3 (D)	9	Same as above but less likely
					IV (1)		3	
23	Retaining Ball Screw O-Ring	Provides sealing surface for retaining ball plug	Missing or broken	None	IV (1)	4 (C)	4	
24	Poppet Valve	Shuts off fuel flow	Fails open	Fuel flow can't be shutoff	I (4)	3 (D)	12	1) Pressure test prior to use 2) Shut off fuel at source
			Cracked or broken	Fuel flow can't be shutoff	I (4)	3 (D)	12	Same as above
			Fails closed	Cannot refuel	IV (1)	3 (D)	3	
25	Valve Shaft	Connects poppet to handle assembly (In-Line with valve link)	Broken	Poppet valve opens; cannot stop fuel flow	I (4)	3 (D)	12	1) Pressure test prior to use 2) Shut off fuel at source
			Bent	Difficult to open or close valve	III (2)	3 (D)	6	Same as above
26	Valve Cotter Pin	Prevents poppet valve from turning (and loosening from shaft)	Missing or broken	1) Valve may loosen and prevent complete fuel shutoff	I (4)	3 (D)	12	Same as above
				2) FOD from pin prevents valve closure. Fuel may leak	II (3)	3 (D)	9	Same as above
27	Valve Link	Connects Poppet Valve to crank assembly (in line with valve shaft).	Broken	Poppet valve fails open; cannot stop fuel flow	I (4)	3 (D)	12	Same as above
			Bent	Difficult to open or close valve	III (2)	3 (D)	6	Same as above
			Installed backwards	Cannot open valve fully	IV (1)	3 (D)	3	
28	Valve Link Pin	Connects valve shaft to valve link	Missing	Poppet valve opens; cannot stop fuel flow	I (4)	3 (D)	12	Same as above
			Bent or broken	Difficult to open or close valve	III (2)	3 (D)	6	
29	Crank Plate	Attaches valve assembly to crank handle	Missing	Poppet valve opens; cannot stop fuel flow	I (4)	3 (D)	12	Same as above
			Bent or broken	Difficult to open or close valve	III (2)	3 (D)	6	
			Improperly installed	Poppet valve won't fully open	III (2)	3 (D)	6	
30	Valve Link Bolt	Fastens valve link to crank plate	Missing	Poppet valve opens; cannot stop fuel flow	I (4)	3 (D)	12	Same as above
			Bent	Difficult to open or close valve	III (2)	3 (D)	6	
31	Valve Link Nut	Fastens valve link bolt to crank plate	Missing or broken	Valve link bolt may back out	I (4)	3 (D)	12	Same as above. In addition, bolt is also threaded into crank plate
32	Cotter Pin	Locks valve link nut	Missing or broken	Nut could back off	I (4)	3 (D)	12	Same as above
				FOD could prevent complete valve closure	II (3)	3 (D)	9	Pressure test prior to use
33	Crank Plate Screws (4)	Fasten crank plate to crank handle	Missing 1 or 2	None	IV (1)	3 (D)	3	Four screws; two are sufficient

NR	COMPONENT	FUNCTION	FAILURE MODE	RESULT OF FAIL	HAZARD CATEGORY	HAZARD PROBABILITY	REAL HAZARD INDEX (RHI)	CORRECTIVE ACTION
			Missing 3 or 4	1) Poppet valve opens; cannot stop fuel flow	I (4)	3 (D)	12	1) Pressure test prior to use 2) Shut off fuel at source
				2) Crank handle may pop up and release fuel	I (4)	3 (D)	12	Same as above
34	Crank Handle	1) Applies force to open poppet valve	Bent shaft	Difficulty in use (binding)	IV (1)	3 (D)	3	
		2) Prevents collar from rotating	Broken shaft	1) Poppet valve opens; cannot stop fuel flow	I (4)	3 (D)	12	1) Pressure test prior to use 2) Shut off fuel at source
				2) Crank handle may come off and release fuel	I (4)	3 (D)	12	Same as above
			Broken locking lug	Possible to rotate collar while refueling; nozzle separates; massive fuel spill	I (4)	3 (D)	12	Prior to refuel, verify integrity by attempting to rotate collar with handle "open" and nozzle attached to aircraft
35	Crank O-Ring	Seals crank shaft tube	Missing or broken	Minor fuel leak	II (3)	3 (D)	9	Same as above
36	Crank Packing	Compresses crank O-Ring	Missing or broken	Minor fuel leak	II (3)	3 (D)	9	Same as above
37	Swivel Bonding Ribbon	Provides sliding contact for electrical bonding	Missing	Nozzle loses electrical continuity	III (2)	3 (D)	6	
			Bent	Binding swivel	IV (1)	3 (D)	3	
38	Dust Cap	Protects nozzle lugs and valve (when not in use)	Torn or missing	None	IV (1)	3 (D)	3	
39	Handlegrip Washer (4)	Provides bearing surface for handlegrip nuts and bolts	Missing, broken or installed backwards	None	IV (1)	3 (D)	3	
40	Secondary O-Ring	Provides seal for swivel bearing	Missing	Fuel leak	II (3)	3 (D)	9	1) Pressure test prior to use 2) Shut off fuel at source
			Torn or broken	Fuel leak	II (3)	3 (D)	9	Same as above

12.0 FAILURE MODES AND EFFECTS ANALYSIS – HOSE END CONTROL VALVE

12.1 Notes that apply to this analysis:

- F. Hazard category, hazard probability, and real hazard index (RHI) are defined herein.
- G. "Visual inspection" means examining the regulator for obvious cracks, damage, and broken lugs, prior to initial pressurization.
- H. "Pressure test prior to use" means pressurizing the regulator to operating fuel pressure, then removing pressure, prior to aircraft arrival.
- I. "Shut off fuel at source" will be the first action for any leak. To further improve operating safety, this procedure should be used for all refueling operations. In addition, fuel flow should be turned on at the source, not at the nozzle.
- J. Item numbers referred to in this section are those used in Figure 1.

12.2 RISK ASSESSMENT - A risk assessment procedure based upon the hazard probability, as well as hazard severity may be required to establish priorities for corrective action and resolution of identified hazards. One example is the real hazard index; a numeric rank ordering of a mathematical combination arrived at by assigning numerical values to the severity category and probability level.

A. Hazard Probability - The probability that a hazard will occur during the planned life expectancy of the system can be described in potential occurrences per unit of time, event, population, item or activity. Assigning a quantitative hazard is generally not possible early in the design process. A qualitative hazard probability may be derived from research, and evaluation of historical safety data from similar systems.

Level	Descriptive word	Specific Individual Item	Fleet or Inventory
A (6)	Frequent	Likely to occur frequently	Continuously experienced
B (5)	Reasonably probable	Will occur several times in life of an item	Will occur frequently
C (4)	Occasional	Likely to occur sometimes in the life of an item	Will occur several times
D (3)	Remote	So unlikely, it can be assumed that this hazard will not be experienced	Unlikely to occur but possible
E (2)	Extremely Improbable	Probability of occurrence cannot be distinguished from zero	So unlikely it can be assumed that this hazard will not be experienced
F (1)	Impossible	Physically impossible to occur	Physically impossible

B. Hazard Severity - Hazard severity categories are defined to provide a qualitative measure of the worst potential consequences resulting from personnel error, environmental conditions, design inadequacies, procedural deficiencies, or system, subsystem or component failure/ malfunction.

Severity Category	Descriptive word	Results
I (4)	Catastrophic	May cause death or system loss
II (3)	Critical	May cause severe injury, or system damage
III (2)	Marginal	May cause minor injury, minor occupational illness, or minor system damage
IV (1)	Negligible	Will not result in injury, occupational illness, or system damage

C. Real Hazard Index (RHI) Matrix - (RHI = Hazard Severity X Probability Level)

		SEVERITY			
		I (4)	II (3)	III (2)	IV (1)
PROBABILITY	A (6)	24	18	12	6
	B (5)	20	15	10	5
	C (4)	16	12	8	4
	D (3)	12	9	6	3
	E (2)	8	6	4	2
	F (1)	4	3	2	1

General guidelines for required action.

RHI

- 1-8 No action required.
- 9-12 Special precautions required, investigate redesign.
- 13-24 Hazardous, redesign necessary or procedural control if redesign is impractical.

12.3 FAILURE MODES AND EFFECTS ANALYSIS (FMEA) – Refer to Figure 1 for component numbers mentioned in column one.

NR	COMPONENT	FUNCTION	FAILURE MODE	RESULT OF FAIL	HAZARD SEVERITY	HAZARD PROBABILITY	REAL HAZARD INDEX (RHI)	CORRECTIVE ACTION
1	Retaining Ring	Retain piston assembly against spring force.	Broken, missing or loose	Unrestrained piston assembly	II (3)	E (2)	6	Inspect prior to installation into system
2	Outer Piston	Regulate outlet pressure.	Broken, scratched or nicked	Uncontrolled pressure regulation, failed to lock-out	III (2)	D (3)	6	
3	Inner piston	Isolate working fluid from reference fluid.	Broken, scratched or nicked	Uncontrolled pressure regulation. Leakage coming out of vent port	III (2)	D (3)	6	
4	Screw	Holds inner and outer pistons together.	Broken, missing, loose or stripped	Uncontrolled pressure regulation, failed to lock-out. Leakage coming out of vent port	III (2)	D (3)	6	
5	Stat-o-seal	Used in conjunction with screw (item 4).	Broken	Uncontrolled pressure regulation, failed to lock-out. Leakage coming out of vent port	III (2)	D (3)	6	
6	Spring	Provides biasing value between reference pressure and outlet pressure.	Broken	Permanent lock-out	III (2)	E (2)	4	
7	Outer Piston Seal	Isolate outlet from inlet when unit is locked out	Broken or nicked	Failed to lock-out	III (2)	E (2)	4	
8	O-Ring	To energize seal (item 7)	Broken	Failed to lock-out	III (2)	F (1)	2	
9	Screw	Holds item 11 (seal retainer) in place	Broken, missing, loose or stripped	Uncontrolled pressure regulation, failed to lock-out. Leakage coming out of vent port	III (2)	D (3)	6	
10	Washer	Used in conjunction with item 9 (screw)	Broken	No effect	IV (1)	E (2)	2	
11	Seal Retainer	Retains Inner piston seals and spacers	Broken or loose	Uncontrolled pressure regulation, failed to lock-out. Leakage coming out of vent port	III (2)	E (2)	4	Inspect prior to installation into system
12	Quad-Ring	To provide sealing seat for ball (item 13)	Broken	Failed to lock-out. Failed to hold locked-out pressure	III (2)	D (3)	6	
13	Ball	To isolate inlet and outlet during lock-out	Broken	Failed to lock-out. Failed to hold locked-out pressure	III (2)	F (1)	2	
14	Spring	Provides biasing value between outlet pressure and inlet pressure	Broken	Failed to lock-out	III (2)	E (2)	4	
15	O-Ring	To provide sealing seat for outer piston (item 2)	Broken	Failed to lock-out	III (2)	D (3)	6	
16	Spacer	To provide segregation between the two sets of seal/O-ring (item 17 and 18)	Broken	Uncontrolled pressure regulation, failed to lock-out. Leakage coming out of vent port	III (2)	E (2)	4	
17	Seal	Isolate working fluid from reference fluid	Broken	Uncontrolled pressure regulation, failed to lock-out. Leakage coming out of vent port	III (2)	E (2)	4	
18	O-Ring	To energize seal (item 17)	Broken	Uncontrolled pressure regulation, failed to lock-out. Leakage coming out of vent port	III (2)	E (2)	4	

NR	COMPONENT	FUNCTION	FAILURE MODE	RESULT OF FAIL	HAZARD SEVERITY	HAZARD PROBABILITY	REAL HAZARD INDEX (RHI)	CORRECTIVE ACTION
19	Seal	To prevent external leakage.	Broken	External leakage	II (3)	E (2)	6	Inspect prior to installation into system
20	O-Ring	To energize seal (item 19)	Broken	External leakage	II (3)	E (2)	6	
21	Breather Assembly	To prevent atmospheric contaminants from entering inner piston cavity	Missing or loose	Contamination of inner piston cavity	IV (1)	E (2)	2	Inspect prior to use
25	Screw Assembly	To provide containment for balls (item 27) and to prevent external leakage	Broken or loose	External leakage	II (3)	E (2)	6	Inspect prior to use
26	O-Ring	To prevent external leakage.	Broken	External leakage	II (3)	E (2)	6	
27	Ball Bearing	To secure mechanical connection to mating part	Broken	Damage ball race	IV (1)	F (1)	1	
28	O-Ring	To prevent external leakage.	Broken	External leakage	II (3)	E (2)	6	Inspect prior to installation into system
29	Housing Assembly	House all components	Cracked	External leakage. Total failure	I (4)	E (2)	8	Inspect prior to use
29	Outer Wear Ring	Provide harden bearing surface to protect aluminum housing	Broken	Exposing aluminum housing ball bearing race to wear.	III (2)	E (2)	4	
29	Inner Wear Ring	Provide harden bearing surface to protect aluminum housing						
31	Continuity clip A	To provide electrical continuity (bonding) to mating component	Broken	No ESD protection	II (3)	E (2)	6	

Aerospace Group
Conveyance Systems Division
9650 Jeronimo Rd
Irvine, CA USA 92618
Ph: (949) 452-9500
Fax: (949) 452-9992



Powering Business Worldwide